

# MIP4

## MINI BATCH TEMPERING

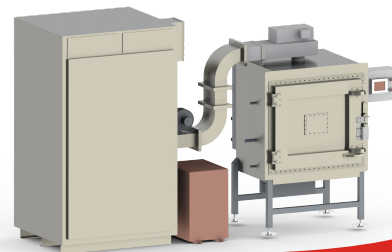

### Tempering to Order

Food service operations that need to temper moderate quantities of food in a hurry and have limited space can rely on the Mini Batch Microwave from Ferrite Microwave Technologies (FMT) for tempering on demand.

The MIP 4 is ideal for batch tempering of frozen meat, fish, poultry, fruit or bakery products in a fast-moving food preparation environment, such as that aboard a cruise ship. This unit can temper up to 1,500 pounds (680 kg) of raw, frozen product per hour. It automatically raises the average temperature of frozen product to between 22 and 29 degrees Fahrenheit (-2 degrees Celsius) at the touch of a button.

A complete system, the MIP 4 consists of a compact microwave oven and a 75 kilowatt microwave generator.

### Advanced Technology

Decades of diligent research and development, as well as real-life tempering trials for customers in widely varied areas of the food processing industry, have driven the industry leading technology contained in the MIP 4 generator.

### Even, Consistent Tempering

The MIP 4 provides uniform heating and enables tempering from low starting temperatures with consistency using FMT's unique rotary table.

Precise computer control of processing variables enables predictable temperature increase - or tempering - and final target temperature attainment. Typically, this microwave oven can temper a 55 pound (25 kg) box of beef in 65 seconds.

### Warranted For Dependability

The MIP 4 Tempering System is warranted for a period of one year. Both in - and out-of-warranty service support is provided by FMT Certified field technicians.

### A Mini System

The MIP 4 has a 3-foot by 4-foot (.9 meter by 1.3 meter) tempering microwave oven and comes complete with its own 75 kilowatt microwave generator.

FMT's MIP 4 industrial microwave tempering unit operates at 915 MHz and produces approximately 260,000 BTUs per hour for superior food processing performance.

### Precise Computer Control

The generator is controlled by a Programmable Logic Controller (PLC) processor. The PLC operates the control software for the generator.

The PLC processor enables constant power operation at preset power levels. It also provides a digital display of status information including actual versus set point power, and fault diagnosis.



### MIP 4 Highlights

- Eliminates tempering rooms or racks, saves space and multiple handling sequences as well as the related mess
- Enables predictable final product temperature attainment
- Adds processing flexibility with tempering on demand for better service
- Improves quality and yield
- Retains flavor and protein compounds for consumers
- Improves sanitation and saves labor costs associated with stripping cartons
- Reduces the disposal of waste cardboard
- Simplifies compliance with government sanitation regulations and guidelines
- Reduces the potential for airborne contaminants to infect food

# MIP4

## MINI BATCH TEMPERING

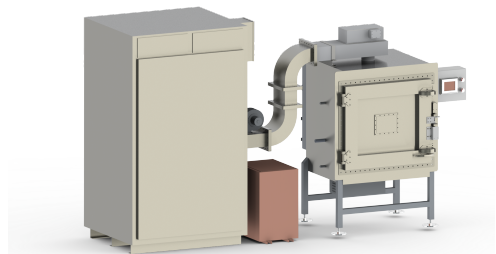

### Reliable, Dependable Industrial Systems

Typical food processing applications include around-the-clock tempering of a wide variety of products for the continuous flow of food from cruise ship galleys.

### Microwave Isolation

The MIP 4 generator is electrically isolated from the process oven by an integral microwave circulator that helps provide long magnetron tube life. Because of the efficiency of FMT's waveguide power transmission, it is possible to install the generator in a remote location.

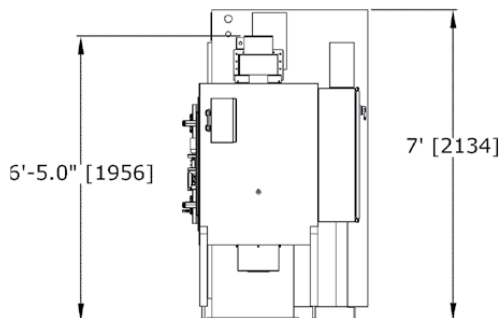
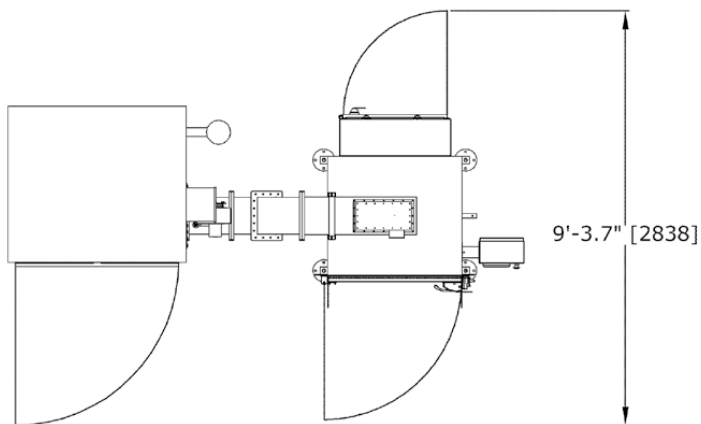

### Sanitation

The MIP 4 tempering oven is stainless steel and is washable. The generator cabinet is a sealed enclosure.

### Generator Controls

All controls for typical generator operation are found on the front of the enclosure. This ensures consistent, uniform and efficient tempering.

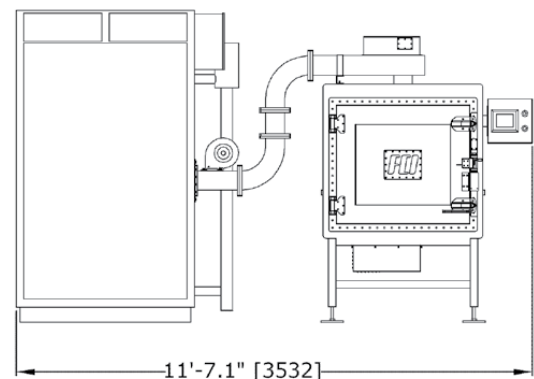

### Safety

Interlocking access doors on the generators meet all applicable government (OSHA and Health and Human Services) safety standards, and provide the safest operating environment available.

Fittings can be provided on the oven to interface with an optional, customer-supplied fire suppression system. Customer supplied light and temperature sensors may be used in the oven to send signals to trigger the system.

### Generator Water Cooling Requirement

FMT microwave generators are water cooled through a heat exchanger using city or local water supply. The system includes a one-inch inflow and outflow pipe. Flow rates depend on the temperature of water entering the heat exchanger (optional temperature control valve is recommended).

### Specification Details

Electrical Specifications (per Generator) United States:

#### INPUT LOAD

480 volts	440 volts
3 phase	3 phase
50/60 cycles	50/60 cycles
72 amps	80 amps
60 KVA	60 KVA

#### MICROWAVE OUTPUT

75 kW  
915 MHz  
Magnetron microwave power source

# Ferrite

## Microwave Technologies

High Power Microwave Systems and Technology

Ferrite Microwave Technologies, LLC  
165 Ledge Street, Nashua, NH 03060  
toll free: 800-854-1466  
tel: 603-881-5234 fax: 603-881-5406  
www.ferriteinc.com